

Packaging Information

TEARING OFF FORCE

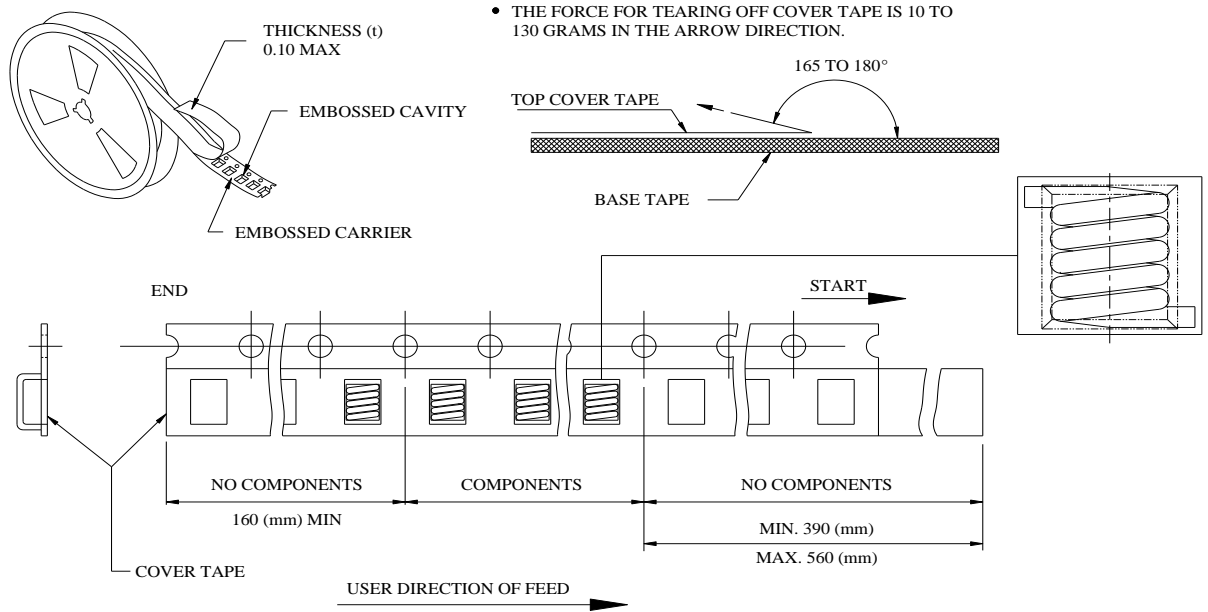

■ CARRIER TAPE REELS (mm)

MATERIAL: PLASTIC

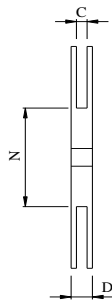
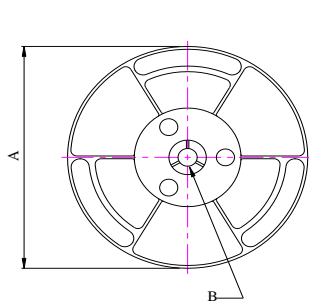

■ DIMENSIONS OF CARRIER TAPE (mm)

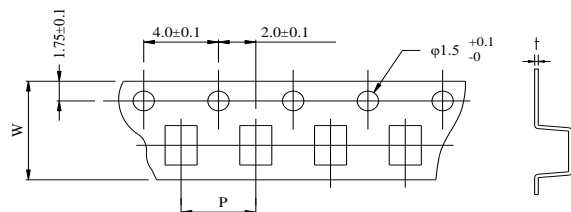

UNIT : mm

	A	B	C	D	N	P	W	t
DIM.	178	15	16.5	20.4	75	8	16	0.25
TOL.	±2.0	±0.5	+1.5/-0	+1.5/-0	±2.0	±0.1	±0.2	±0.05

UNIT : mm

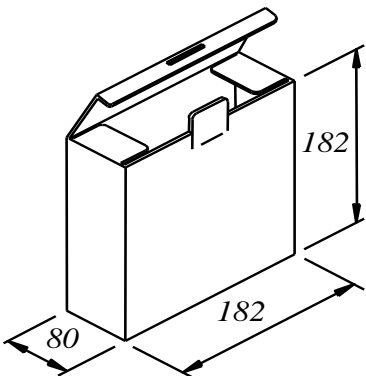

- CONSTRUCTION:
THE CASE CONTAINS 3-16mm WIDE CARRIER TAPES.
QTY :500 / REEL

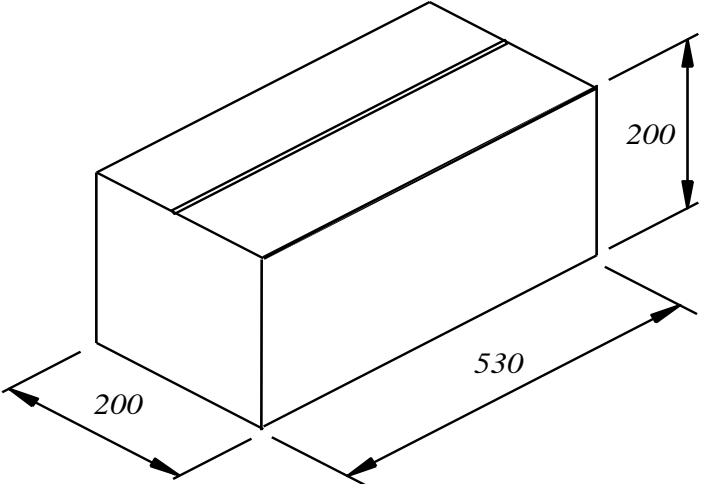

TOTAL Q'TY : 9,000 PCS